



BAKING MIXER

SERVING THE FOOD INDUSTRY SINCE 1951

HEAVY-DUTY 20-QT BAKING MIXER WITH TIMER AND GUARD

Item: 43560

Model: MX-CN-0020

Designed with an overload protection to effectively guarantee long-life service. Heat is spread in axial direction. These units are equipped with a #12 drive hub.



WARRANTY

PARTS AND LABOR



Authorized Dealer

BAKING MIXER

HEAVY-DUTY 20-QT MIXER WITH TIMER AND GUARD



Upgraded gear drives for maximum strength and efficiency. Comes with a heavy-duty 2-HP motor. The unit is also equipped with a guard and timer. Stainless steel bowl, wire whip, flat beater and hook included.



Equipped with guard

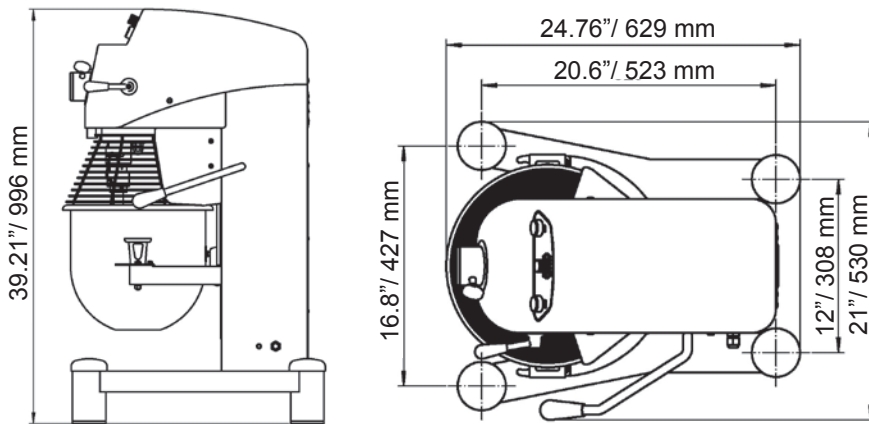

Control panel

TECHNICAL SPECIFICATION			
ITEM NUMBER	43560		
MODEL	MX-CN-0020		
POWER	2 HP / 1.5 kW		
CAPACITY	20 QT		
SHAFT SPEED (R/MIN)	97-120 First Speed	220-271 Second Speed	316-389 Third Speed
	TIMER		
	Yes		
GUARD			
Yes			
ELECTRICAL			
110 V / 60Hz / 1			
PACKAGING WEIGHT			
275 lbs. / 125 kg.			
DIMENSIONS (DWH)			
24.76" x 16.18" x 39.21" / 629 x 427 x 996 mm			
PACKAGING DIMENSIONS			
25" x 29" x 44" / 635 x 737 x 1117.6 mm			



Accessories included

NEMA
5 - 15
125 VAC / 15 AMP

OMCAN INC.

Telephone: 1-800-465-0234
 Fax: (905) 607-0234
 Email: sales@omcan.com
 Website: www.omcan.com



Follow us to keep up to date with the latest news and offers

